

Transient Voltage Suppressors (TVS) Data Sheet

Features

- Glass passivated junction
- Low zener impedance
- Excellent clamping capability
- 1500W peak pulse power capability at 10/1000 μ s waveform,
- repetition rate (duty cycle): 0.01%
- Fast response time
- Typical I_R less than 1 μ A above 12V.
- High Temperature soldering guaranteed: 265 $^{\circ}$ C/10 seconds/.375",
- (9.5mm) lead length, 5lbs (2.3kg) tension
- Plastic package has underwriters laboratory flammability 94V-0
- Meets MSL level 1, per J-STD-020.
- AEC-Q101 qualified (Automotive grade with suffix "Q".)
- Expsemi electronics
- UL Certification:E492977



Mechanical Data

- Case: JEDEC DO-201 Moulded plastic
- Terminal: Axial leads, solderable per MIL-STD-750, Method 2026
- Polarity: Color band denotes cathode except bi-directional models
- Mounting Position: Any

Applications

- AC/DC power supply
- I/O interface
- Low frequency signal transmission line

Maximum Ratings and Characteristics

Ratings at 25 $^{\circ}$ C ambient temperature unless otherwise specified.

Rating	Symbol	Value	Units
Peak pulse power dissipation at 10/1000 μ s waveform (Note1, Fig.1)	P_{PPM}	Minimum 1500	Watts
Peak pulse current of at 10/1000 μ s waveform (Note 1, Fig.3)	I_{PPM}	See Table	Amps
Steady state power dissipation at $T_L=75^{\circ}$ C (Fig.5)	$P_{M(AV)}$	6.5	Watts
Peak forward surge current, 8.3ms single half sine-wave superimposed on rated load, (JEDEC Method) (Note2, Fig.6)	I_{FSM}	200	Amps
Operating junction and Storage Temperature Range.	T_J, T_{STG}	-55 to +175	$^{\circ}$ C
Typical thermal resistance junction to lead	$R_{\theta JL}$	15	$^{\circ}$ C/W
Typical thermal resistance junction to ambient	$R_{\theta JA}$	75	$^{\circ}$ C/W

Notes: 1. Non-repetitive current pulse, per Fig.3 and derated above $T_A=25^{\circ}$ C per Fig.2.

2. 8.3ms single half sine-wave, or equivalent square wave, duty cycle=4 pulses per minutes maximum.

Dimensions (DO-201)

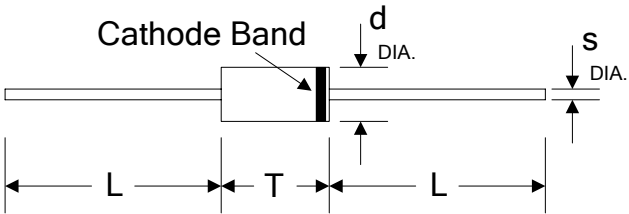
 <p>The diagram shows a side view of a DO-201 package with dimensions L, T, d, and s. A cathode band is indicated on the top surface. The dimensions are defined as follows: L is the length of the leads, T is the thickness of the body, d is the diameter of the leads, and s is the diameter of the body.</p>	Symbol	Millimeters		Inches	
		Min.	Max.	Min.	Max.
	L	25.40	-	1.000	-
	T	7.20	9.50	0.285	0.375
	d	4.80	5.30	0.190	0.210
	s	0.96	1.07	0.038	0.042

Electrical Characteristics ($T_A=25^\circ\text{C}$)

Part Number		Reverse Stand-Off Voltage	Breakdown Voltage @ I_T	Test Current	Maximum Clamping Voltage @ I_{PP}	Peak Pulse Current	Reverse Leakage @ V_{RWM}
Unidirectional	Bidirectional	$V_{RWM}(V)$	$V_{BR}(V)$	$I_T(mA)$	$V_C(V)$	$I_{PP}(A)$	$I_R(\mu A)$
1.5KE6.8A	1.5KE6.8CA	5.80	6.45~7.14	10	10.5	144.8	1000
1.5KE7.5A	1.5KE7.5CA	6.40	7.13~7.88	10	11.3	134.5	500
1.5KE8.2A	1.5KE8.2CA	7.02	7.79~8.61	10	12.1	125.6	200
1.5KE9.1A	1.5KE9.1CA	7.78	8.65~9.55	1	13.4	113.4	50
1.5KE10A	1.5KE10CA	8.55	9.50~10.50	1	14.5	104.8	10
1.5KE11A	1.5KE11CA	9.40	10.50~11.60	1	15.6	97.4	5
1.5KE12A	1.5KE12CA	10.20	11.40~12.60	1	16.7	91.0	5
1.5KE13A	1.5KE13CA	11.10	12.40~13.70	1	18.2	83.5	1
1.5KE15A	1.5KE15CA	12.80	14.30~15.80	1	21.2	71.7	1
1.5KE16A	1.5KE16CA	13.60	15.20~16.80	1	22.5	67.6	1
1.5KE18A	1.5KE18CA	15.30	17.10~18.90	1	25.2	60.3	1
1.5KE20A	1.5KE20CA	17.10	19.00~21.00	1	27.7	54.9	1
1.5KE22A	1.5KE22CA	18.80	20.90~23.10	1	30.6	49.7	1
1.5KE24A	1.5KE24CA	20.50	22.80~25.20	1	33.2	45.8	1
1.5KE27A	1.5KE27CA	23.10	25.70~28.40	1	37.5	40.5	1
1.5KE30A	1.5KE30CA	25.60	28.50~31.50	1	41.4	36.7	1
1.5KE33A	1.5KE33CA	28.20	31.40~34.70	1	45.7	33.3	1
1.5KE36A	1.5KE36CA	30.80	34.20~37.80	1	49.9	30.5	1
1.5KE39A	1.5KE39CA	33.30	37.10~41.00	1	53.9	28.2	1

Electrical Characteristics ($T_A=25^{\circ}\text{C}$)

Part Number		Reverse Stand-Off Voltage	Breakdown Voltage @ I_T	Test Current	Maximum Clamping Voltage @ I_{PP}	Peak Pulse Current	Reverse Leakage @ V_{RWM}
Unidirectional	Bidirectional	$V_{RWM}(V)$	$V_{BR}(V)$	$I_T(mA)$	$V_C(V)$	$I_{PP}(A)$	$I_R(\mu A)$
1.5KE43A	1.5KE43CA	36.80	40.90~45.20	1	59.3	25.6	1
1.5KE47A	1.5KE47CA	40.20	44.70~49.40	1	64.8	23.5	1
1.5KE51A	1.5KE51CA	43.60	48.50~53.60	1	70.1	21.7	1
1.5KE56A	1.5KE56CA	47.80	53.20~58.80	1	77.0	19.7	1
1.5KE62A	1.5KE62CA	53.00	58.90~65.10	1	85.0	17.9	1
1.5KE68A	1.5KE68CA	58.10	64.60~71.40	1	92.0	16.5	1
1.5KE75A	1.5KE75CA	64.10	71.30~78.80	1	103.0	14.8	1
1.5KE82A	1.5KE82CA	70.10	77.90~86.10	1	113.0	13.5	1
1.5KE91A	1.5KE91CA	77.80	86.50~95.50	1	125.0	12.2	1
1.5KE100A	1.5KE100CA	85.50	95.00~105.00	1	137.0	11.1	1
1.5KE110A	1.5KE110CA	94.00	105.00~116.00	1	152.0	10.0	1
1.5KE120A	1.5KE120CA	102.00	114.00~126.00	1	165.0	9.2	1
1.5KE130A	1.5KE130CA	111.00	124.00~137.00	1	179.0	8.5	1
1.5KE150A	1.5KE150CA	128.00	143.00~158.00	1	207.0	7.3	1
1.5KE160A	1.5KE160CA	136.00	152.00~168.00	1	219.0	6.9	1
1.5KE170A	1.5KE170CA	145.00	162.00~179.00	1	234.0	6.5	1
1.5KE180A	1.5KE180CA	154.00	171.00~189.00	1	246.0	6.2	1
1.5KE200A	1.5KE200CA	171.00	190.00~210.00	1	274.0	5.5	1
1.5KE220A	1.5KE220CA	185.00	209.00~231.00	1	328.0	4.6	1
1.5KE250A	1.5KE250CA	214.00	237.00~263.00	1	344.0	4.4	1
1.5KE300A	1.5KE300CA	256.00	285.00~315.00	1	414.0	3.7	1
1.5KE350A	1.5KE350CA	300.00	332.00~368.00	1	482.0	3.2	1
1.5KE400A	1.5KE400CA	342.00	380.00~420.00	1	548.0	2.8	1
1.5KE440A	1.5KE440CA	376.00	418.00~462.00	1	602.0	2.5	1
1.5KE480A	1.5KE480CA	408.00	456.00~504.00	1	658.0	2.3	1
1.5KE510A	1.5KE510CA	434.00	485.00~535.00	1	698.0	2.1	1
1.5KE530A	1.5KE530CA	450.00	503.50~556.50	1	725.0	2.1	1
1.5KE540A	1.5KE540CA	459.00	513.00~567.00	1	740.0	2.0	1
1.5KE550A	1.5KE550CA	467.00	522.50~577.50	1	760.0	2.0	1

Notes: For bidirectional type having V_{RWM} of 10V and less, the I_R limit is double.

Ratings and Characteristic Curves ($T_A=25^{\circ}\text{C}$ unless otherwise noted)

Figure 1. Peak Pulse Power Rating Curve

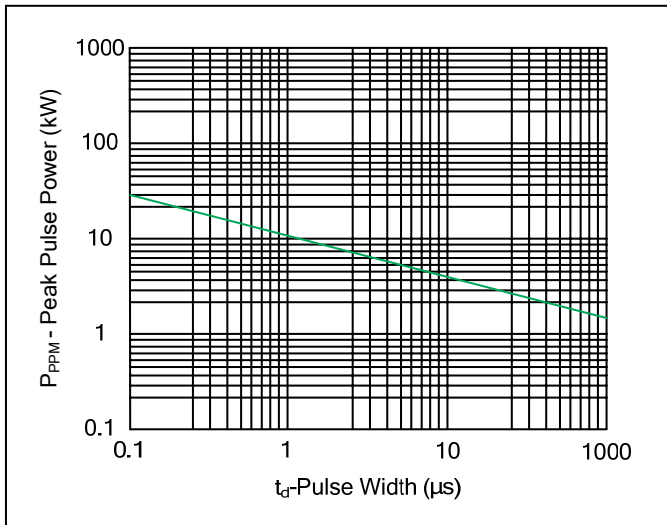

Figure 2. Pulse Derating Curve

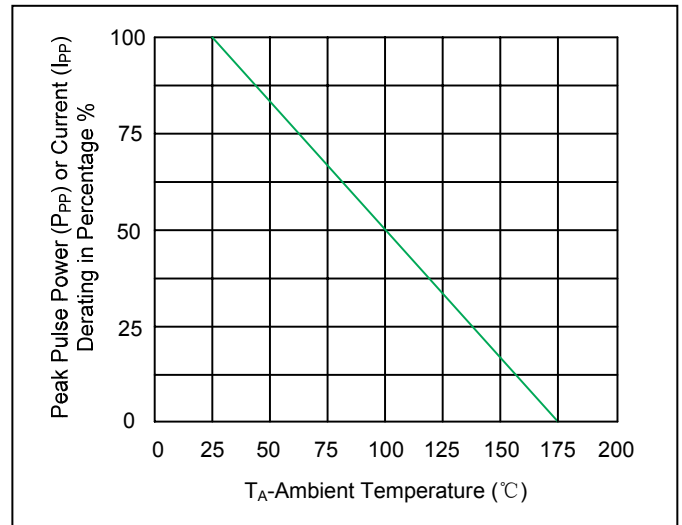

Figure 3. Pulse Waveform

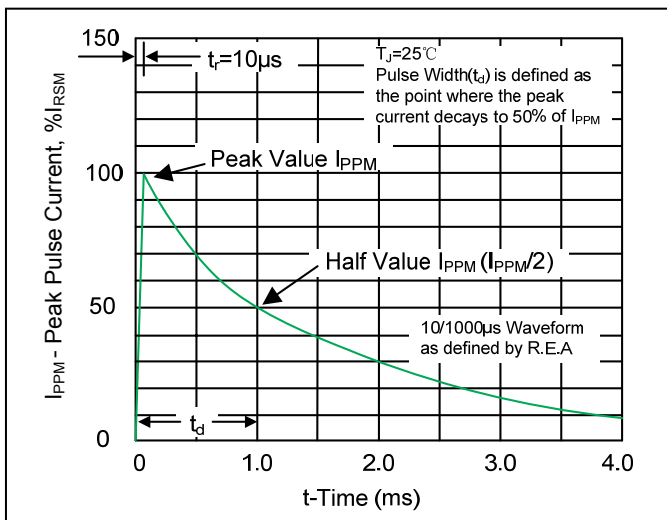

Figure 4. Typical Junction Capacitance

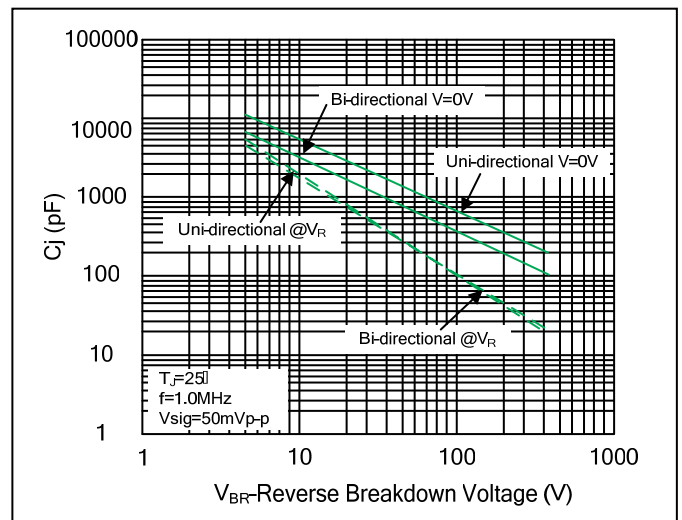

Figure 5. Steady State Power Dissipation Derating Curve

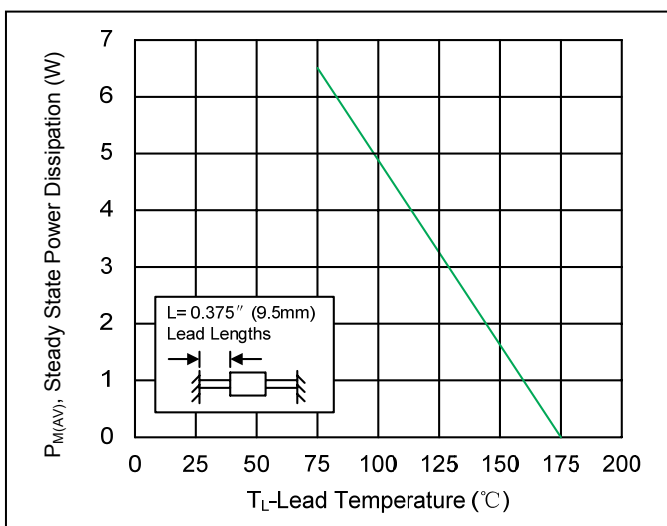
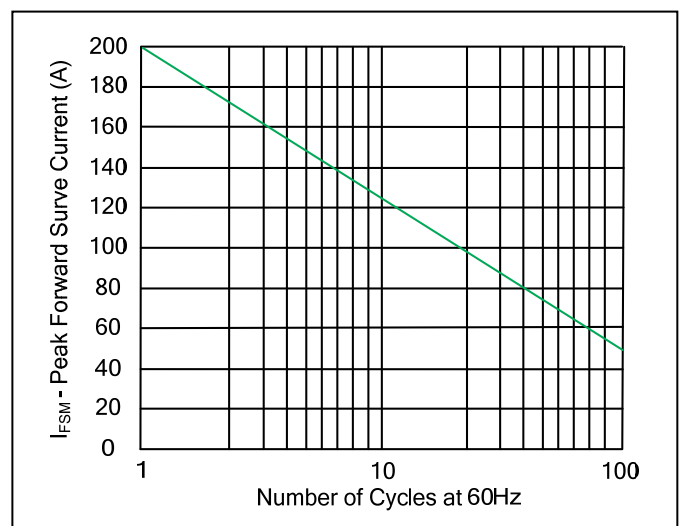

Figure 6. Maximum Non-Repetitive Forward Surge Current Uni-Directional Only



Recommended Soldering Conditions

Soldering Parameters

Reflow Condition		Lead-free assembly
Pre Heat	- Temperature Min ($T_{s(min)}$)	150°C
	- Temperature Max ($T_{s(max)}$)	200°C
	- Time (min to max) (t_s)	60 – 180 secs
Average ramp up rate (Liquidus Temp (T_A) to peak)		3°C/second max
$T_{s(max)}$ to T_A - Ramp-up Rate		3°C/second max
Reflow	- Temperature (T_A) (Liquidus)	217°C
	- Time (min to max) (t_s)	60 – 150 seconds
Peak Temperature (T_p)		260 ^{+0/-5} °C
Time within 5°C of actual peak Temperature (t_p)		20 – 40 seconds
Ramp-down Rate		6°C/second max
Time 25°C to peak Temperature (T_p)		8 minutes Max.
Do not exceed		260°C

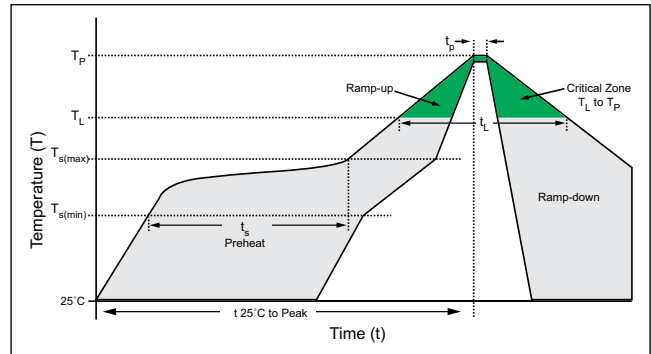

Flow/Wave Soldering (Solder Dipping)

Peak Temperature :	265°C
Dipping Time :	10 seconds
Soldering :	1 time

Physical Specifications

Weight	0.015oz., 0.4g
Case	JEDEC DO-204AC (DO-15) molded plastic body over passivated junction.
Polarity	Color band denotes the cathode except Bipolar.
Terminal	Matte Tin axial leads, solderable per JESD22-B102.

Environmental Specifications

High Temp. Storage	JESD22-A103
HTRB	JESD22-A108
Temperature Cycling	JESD22-A104
H3TRB	JESD22-A101
RSH	JESD22-B106

Dimensions

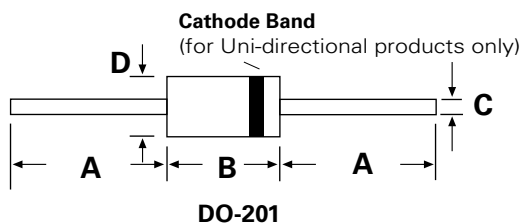

Dimensions	Inches		Millimeters	
	Min	Max	Min	Max
A	1.000	-	25.40	-
B	0.285	0.375	7.20	9.50
C	0.038	0.042	0.96	1.07
D	0.190	0.210	4.80	5.30

Part Numbering System

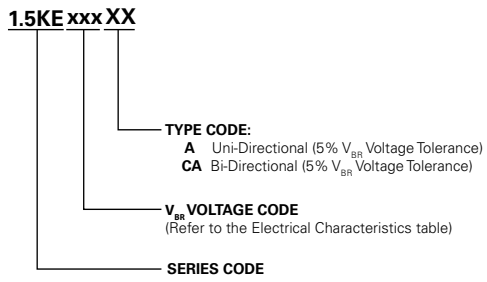

Part Marking System

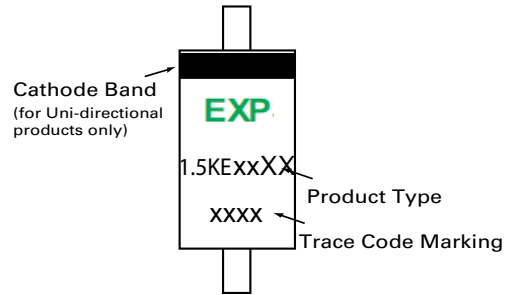

Packaging

Part Number	Component Package	Quantity	Packaging Option	Packaging Specification
1.5KExxxXX	DO-201	1000	Tape & Reel	EIA STD RS-296

Tape and Reel Specification

Tape	Symbol	Dimension (mm)
	A	10.0±0.5
	B	53.0±1.0
	Z	1.2Max.
	T	6.0±0.4
	E	0.8Max.
	L1-L2	1.0Max.
	C	